

**Report Number: QIP-ASI1731091**

**Audit Date :** 20 Oct., 2017

This report is issued by Focus Technology Co., Ltd. (Made-in-China.com) and the supervising inspectorate (SGS-CSTC Standards Technical Services Co., Ltd.) to confirm that:

**Company Name :** Hangzhou ENPAI Trading Co., Ltd.  
 杭州恩派贸易有限公司  
 Remark: The Company also used company name of ENPAI GROUP LTD (registered in the United Kingdom) in business. Shareholders of two companies are couple.

**Showroom :** <http://enpai086.en.made-in-china.com>

**Address :** Room 1401-1402, Floor 14, Building K, Taijia Plaza, No.972, Moganshan Road, Gongshu District, Hangzhou, Zhejiang, China

**Product :** Promotional Gifts, Bags, Cups and Mugs, Pens

has been on site audited for the Following Scope of Activity

1. General Information
2. Foreign Trade Capacity
3. Working Environment
4. Photos



**General Comments:**

Hangzhou ENPAI Trading Co., Ltd. is a trading company with 24 employees; it was established in 2012, located in Room 1401-1402, Floor 14, Building K, Taijia Plaza, No.972, Moganshan Road, Gongshu District, Hangzhou, Zhejiang, China. The company occupies an area of more than 462 square meters. The company has successful foreign trading experience in North America, South America, Europe and Mideast.



Sign for and on behalf of  
 SGS-CSTC Standards Technical Services Co., Ltd.



Unless otherwise agreed in writing, this document is issued by the Company under its General Conditions of Service accessible at <http://www.sgs.com/en/Terms-and-Conditions.aspx> Attention is drawn to the limitation of liability, indemnification and jurisdiction issues defined therein. Any holder of this document is advised that information contained hereon is solely limited to visual examination of the safely and readily accessible portions of the consignment and reflects the Company's findings at the time of its intervention only and within the limits of Client's instructions, if any. The Company's sole responsibility is to its Client and this document does not exonerate parties to a transaction from exercising all their rights and obligations under the transaction documents. Any unauthorized alteration, forgery or falsification of the content or appearance of this document is unlawful and offenders may be prosecuted to the fullest extent of the law.

Attention: To check the authenticity of testing /inspection report & certificate, please contact us at telephone: (86-755) 8307 1443, or email: [CN.Doccheck@sgs.com](mailto:CN.Doccheck@sgs.com)

Page No.: 1 of 9

5/F, B-4 Building, Zijin (Baixia) Technology Incubation Special Park, No.1 Guanghua Road, Nanjing, China 210014 t (86-25) 87128385 f (86-25) 83407773 www.sgsgroup.com.cn  
 中国·南京·秦淮区光华路1号紫金白下创业特别社区4号楼B幢5楼 邮编: 210014 t (86-25) 87128385 f (86-25) 83407773 e as.cn@sgs.com

# SUPPLIER ASSESSMENT REPORT

Audited Company	Hangzhou ENPAI Trading Co., Ltd.
Audited Site:	Room 1401-1402, Floor 14, Building K, Taijia Plaza, No.972, Moganshan Road, Gongshu District, Hangzhou, Zhejiang, China

Consigner of Assessment	Made-in-China.com		
Audit Type	<input checked="" type="checkbox"/> Initial Audit <input type="checkbox"/> Re-audit		
Audit Date	20 Oct., 2017	Verify Report	<a href="http://www.sgs.com/ecv">www.sgs.com/ecv</a>
Auditor	Nemo Hu	Reviewed by	Simon Wang

## CONTENTS

- Part A: General Information**
  - Section 1: Company Overview
  - Section 2: Human Resources
- Part B: Foreign Trade Capacity**
  - Section 1: Export Overall Situation
  - Section 2: Export Business Capacity
  - Section 3: Supplier Management
  - Section 4: After-sales Service Capacity
- Part C: Product Research & Development Capacity**
  - Section 1: Product Research & Development Capacity
- Part D: Management System and Product Certification**
  - Section 1: Management System(s) and Product Certification
- Part E: Production Capacity & Quality Control**
  - Section 1: Production Capacity Section
  - Section 2: Production Process Control
- Part F: Financial Position**
  - Section 1: Financial Data
  - Section 2: Key Performance Indications
  - Section 3: Banking
  - Section 4: Product Insurance
- Part G: Working Environment**
  - Section 1: Working Environment
- Part H: Energy Saving and Emission Reduction**
  - Section 1: Environmental Management
  - Section 2: Water, Gas and Noise Control
- Part I: Industry Information**
  - Section 1: Industry Information
- Part J: Photos**
  - Section 1: Photos of Documents
  - Section 2: Photos of Company



Unless otherwise agreed in writing, this document is issued by the Company under its General Conditions of Service accessible at <http://www.sgs.com/en/Terms-and-Conditions.aspx>. Attention is drawn to the limitation of liability, indemnification and jurisdiction issues defined therein. Any holder of this document is advised that information contained hereon is solely limited to visual examination of the safely and readily accessible portions of the consignment and reflects the Company's findings at the time of its intervention only and within the limits of Client's instructions, if any. The Company's sole responsibility is to its Client and this document does not exonerate parties to a transaction from exercising all their rights and obligations under the transaction documents. Any unauthorized alteration, forgery or falsification of the content or appearance of this document is unlawful and offenders may be prosecuted to the fullest extent of the law.

Attention: To check the authenticity of testing/inspection report & certificate, please contact us at telephone: (86-755) 8307 1443, or email: [CN.Doccheck@sgs.com](mailto:CN.Doccheck@sgs.com)

Page No.: 2 of 9

SGS-CSI Standards Technical Services Co., Ltd.  
Consumer and

5/F, B-4 Building, Zjin (Baixia) Technology Incubation Special Park, No.1 Guanghua Road, Nanjing, China 210014 t (86-25) 87128385 f (86-25) 83407773 www.sgs.com.cn  
 中国·南京·秦淮区光华路1号紫金白下创业特别社区4号楼B幢5楼 邮编: 210014 t (86-25) 87128385 f (86-25) 83407773 e as.cn@sgs.com

## Part A: General Information

### Section 1: Company Overview

1.1 Legal Validity			
Does the company have a valid business license?	<input checked="" type="checkbox"/> Yes <input type="checkbox"/> No <input type="checkbox"/> Others	Registration Number	91330105599594318Y
Year of established	31 Oct., 2012	Valid Date	30 Oct., 2032
Registered address	Room 1401, Floor 14, Building K, Taijia Plaza, No.972, Moganshan Road, Gongshu District, Hangzhou, Zhejiang, China		
Actual address	Room 1401-1402, Floor 14, Building K, Taijia Plaza, No.972, Moganshan Road, Gongshu District, Hangzhou, Zhejiang, China		
Does the company in abnormal operation status list of industrial and commercial bureau?	No		
Registered capital	RMB 500,000		
Name of legal representative	Mr. Yu Zhang		
Business scope	Wholesale and retail: Crafts, pet supplies, the class I medical devices, furniture, office supplies, rubber and plastic products, building materials, metal materials, hardware and electrical equipment, mechanicals and electrical equipment, auto parts, sanitary wares, daily provisions, communications equipment, computer accessories, wire and cable, lighting equipment, needles textiles, household electrical appliances, clothing, bags; Import and export of goods and technologies (except the forbidden project by law, law and regulations limited project needs operation permit)		
1.2 Basic Information			
Contact person	Mr. Billy Zhang		
Phone number	0086-571-89190248	Fax number	0086-571-89190240
URL/Web address	<a href="http://www.enpai-promotions.com">http://www.enpai-promotions.com</a>		
Company type	<input type="checkbox"/> Manufacturer <input checked="" type="checkbox"/> Trading Company <input type="checkbox"/> Combined <input type="checkbox"/> Group Corporation		
Type of ownership	<input checked="" type="checkbox"/> Limited Company <input type="checkbox"/> Public Company <input type="checkbox"/> Foreign joint venture <input type="checkbox"/> State-Owned <input type="checkbox"/> Private Owner <input type="checkbox"/> Wholly foreign-owned enterprises		
Associated company	<ul style="list-style-type: none"> <li>■ Audited company: <b>Hangzhou ENPAI Trading Co., Ltd.</b></li> <li>■ Associated company: <b>ENPAI GROUP LTD</b></li> <li>■ The relationship of two companies:                             <ul style="list-style-type: none"> <li><input checked="" type="checkbox"/> Shareholders of two companies are couple.</li> </ul> </li> </ul>		
Products manufactured / sold scope	Promotional Gifts, Bags, Cups and Mugs, Pens		
1.3 Company Building Information			
According to:	<input type="checkbox"/> Land certificate <input type="checkbox"/> Real estate certificate <input checked="" type="checkbox"/> Lease agreement <input checked="" type="checkbox"/> Observation Estimated on site		
The company area 462 square meters The land occupies square meters. Confidential The offices occupy 462 square meters. The workshops occupy square meters. N/A			



Unless otherwise agreed in writing, this document is issued by the Company under its General Conditions of Service accessible at <http://www.sgs.com/en/Terms-and-Conditions.aspx>. Attention is drawn to the limitation of liability, indemnification and jurisdiction issues defined therein. Any holder of this document is advised that information contained hereon is solely limited to visual examination of the safely and readily accessible portions of the consignment and reflects the Company's findings at the time of its intervention only and within the limits of Client's instructions, if any. The Company's sole responsibility is to its Client and this document does not exonerate parties to a transaction from exercising all their rights and obligations under the transaction documents. Any unauthorized alteration, forgery or falsification of the content or appearance of this document is unlawful and offenders may be prosecuted to the fullest extent of the law.

Attention: To check the authenticity of testing / inspection report & certificate, please contact us at telephone: (86-755) 8307 1443, or email: [CN.Doccheck@sgs.com](mailto:CN.Doccheck@sgs.com)

Page No.: 3 of 9

5/F, B-4 Building, Zjin (Baixia) Technology Incubation Special Park, No.1 Guanghua Road, Nanjing, China 210014 t (86-25) 87128385 f (86-25) 83407773 www.sgs.com.cn  
 中国·南京·秦淮区光华路1号紫金白下创业特别社区4号楼B幢5楼 邮编: 210014 t (86-25) 87128385 f (86-25) 83407773 e as.cn@sgs.com

## Section 2: Human Resources

### 2.1 Company Chart

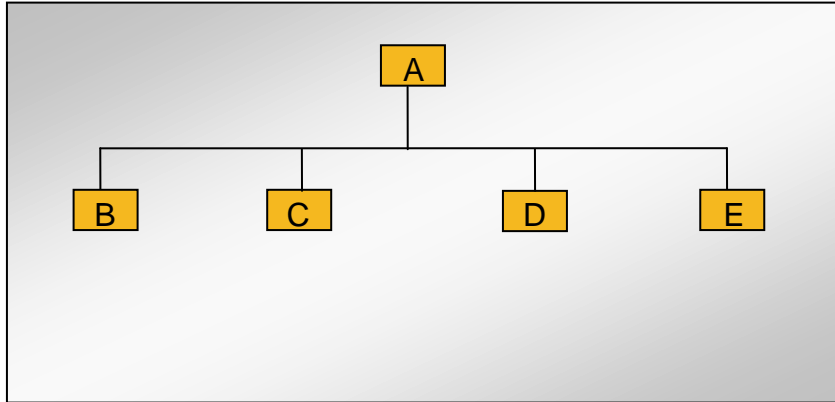

### 2.2 Explanation of Code and Employee Details

Code	Department	Number of employees
A	General Manager	1
B	Sales Dept.	18
C	Design Dept.	2
D	Quality Control Dept.	2
E	Admin. Dept.	1
<b>Number in total:</b>		24

### 2.3 Key Staff

Title	Full name	Education	Working experience for this trade / total experience
General Manager	Mr. Billy Zhang	University	13/13 years

Remark: Above information of key staff was based on interview with company representative.

## Part B: Foreign Trade Capacity

### Section 1: Export Overall Situation

1.1 Export Overall Situation	
Does the company have a valid Import and Export license?	<input checked="" type="checkbox"/> Yes <input type="checkbox"/> No
The import and export enterprise code.	91330105599594318Y
The number of foreign trading staff with relevant trading experience.	<input type="checkbox"/> within 1 year staff <input checked="" type="checkbox"/> 1-5 years 12 staffs <input checked="" type="checkbox"/> 6-10 years 4 staffs <input checked="" type="checkbox"/> over 10 years 3 staffs Total 19 staffs
The language freely used by foreign trade staff	<input checked="" type="checkbox"/> English <input type="checkbox"/> others:
Annual revenue of previous year	Confidential
Annual export revenue of previous year	Confidential
Estimated export revenue for this year.	Confidential
Overseas agent / branch	<input type="checkbox"/> Yes <input checked="" type="checkbox"/> No
Nearest port	Ningbo Port
Acceptable quotation terms	<input checked="" type="checkbox"/> FOB <input checked="" type="checkbox"/> CIF <input checked="" type="checkbox"/> CFR
Acceptable payment terms	<input checked="" type="checkbox"/> LC <input checked="" type="checkbox"/> T/T <input checked="" type="checkbox"/> D/P <input checked="" type="checkbox"/> PayPal <input checked="" type="checkbox"/> Western Union <input checked="" type="checkbox"/> Small-amount payment
Average lead time (Peak Season)	<input type="checkbox"/> within 15 workday <input checked="" type="checkbox"/> one month <input type="checkbox"/> 2-3 months <input type="checkbox"/> 4-6 months <input type="checkbox"/> 6-12 months <input type="checkbox"/> more time
Average lead time (Off Season)	<input type="checkbox"/> within 15 workday <input checked="" type="checkbox"/> one month <input type="checkbox"/> 2-3 months <input type="checkbox"/> 4-6 months <input type="checkbox"/> 6-12 months <input type="checkbox"/> more time

### Section 2: Export Business Capacity

2.1 Market Distribution (please list top three areas)		
Market	Main Product	Main client
<input checked="" type="checkbox"/> North America	Promotional Gifts, Bags, Cups and Mugs, Pens	Confidential
<input checked="" type="checkbox"/> South America	Promotional Gifts, Bags, Cups and Mugs, Pens	Confidential
<input checked="" type="checkbox"/> Europe	Promotional Gifts, Bags, Cups and Mugs, Pens	Confidential
<input checked="" type="checkbox"/> Southeast Asia/ Mideast	Promotional Gifts, Bags, Cups and Mugs, Pens	Confidential
<input type="checkbox"/> Africa		
<input type="checkbox"/> East Asia (Japan/ South Korea)		
<input type="checkbox"/> Australia		
<input type="checkbox"/> Domestic		
<input type="checkbox"/> Others		



Unless otherwise agreed in writing, this document is issued by the Company under its General Conditions of Service accessible at <http://www.sgs.com/en/Terms-and-Conditions.aspx> Attention is drawn to the limitation of liability, indemnification and jurisdiction issues defined therein. Any holder of this document is advised that information contained hereon is solely limited to visual examination of the safely and readily accessible portions of the consignment and reflects the Company's findings at the time of its intervention only and within the limits of Client's instructions, if any. The Company's sole responsibility is to its Client and this document does not exonerate parties to a transaction from exercising all their rights and obligations under the transaction documents. Any unauthorized alteration, forgery or falsification of the content or appearance of this document is unlawful and offenders may be prosecuted to the fullest extent of the law.

Attention: To check the authenticity of testing / inspection report & certificate, please contact us at telephone: (86-755) 8307 1443, or email: [CN.Doccheck@sgs.com](mailto:CN.Doccheck@sgs.com)

Page No.: 5 of 9

SGS-CSI Standards Technical Services Co., Ltd.  
Consumer and Industrial Products

5/F, B-4 Building, Zijin (Baixia) Technology Incubation Special Park, No.1 Guanghua Road, Nanjing, China 210014 t (86-25) 87128385 f (86-25) 83407773 www.sgsgroup.com.cn  
中国·南京·秦淮区光华路1号紫金白下创业特别社区4号楼B幢5楼 邮编: 210014 t (86-25) 87128385 f (86-25) 83407773 e as.cn@sgs.com

### Section 3: Supplier Management

3.1 Supplier Management		
Item	Content	Observations /Comments
1	Does the company establish and implement an effective suppliers' assessment procedure?	<input type="checkbox"/> Have the written procedures and followed records <input type="checkbox"/> Have the written procedures but no records <input type="checkbox"/> Have relevant records without written procedure <input checked="" type="checkbox"/> No written procedures or followed records <input type="checkbox"/> Other
2	Does the company have an updated list of approved suppliers?	<input type="checkbox"/> The approved suppliers list was updated in _____ <input type="checkbox"/> Have the written suppliers without approved signature or date. <input checked="" type="checkbox"/> Provided some suppliers names <input type="checkbox"/> No approved suppliers list <input type="checkbox"/> Other

### Section 4: After-sales Service Capacity

4.1 After-sales Service Capacity		
Item	Content	Observations /Comments
1	Is there a procedure to conduct random product inspection after final packaging in place?	<input type="checkbox"/> Have clear standards and written inspection records <input type="checkbox"/> No written standards but had inspection reports <input type="checkbox"/> Have the procedures but no inspection records <input checked="" type="checkbox"/> It's not necessary to carry out the inspection <input type="checkbox"/> Other
2	Is there a clear procedure for handling customer complaints?	<input type="checkbox"/> Has the clear procedure and followed records <input type="checkbox"/> Has the procedure but no written records. <input type="checkbox"/> No written procedures or records. <input checked="" type="checkbox"/> Other The sales staff handled customer complaints via phone and emails.
3	Can the finished/packaged product be traced by lot identification to the appropriate raw materials test reports?	<input type="checkbox"/> Have the procedures to trace the raw materials. <input type="checkbox"/> Can trace main materials <input type="checkbox"/> Can trace production date. <input type="checkbox"/> Can't trace products <input checked="" type="checkbox"/> Other In general, it was based on the trace system of manufacturer.
4	Are corrective & preventive actions mechanism established and implemented effectively (including the suppliers/ sub-contractors control, incoming inspection, process control, final inspection and customer complaint)?	<input type="checkbox"/> Has the clear procedure and followed records <input type="checkbox"/> Has the procedure but no written records. <input type="checkbox"/> No written procedures or records. <input checked="" type="checkbox"/> Other In general, it was based on the manufacturer's quality management system.



Unless otherwise agreed in writing, this document is issued by the Company under its General Conditions of Service accessible at <http://www.sgs.com/en/Terms-and-Conditions.aspx> Attention is drawn to the limitation of liability, indemnification and jurisdiction issues defined therein. Any holder of this document is advised that information contained hereon is solely limited to visual examination of the safely and readily accessible portions of the consignment and reflects the Company's findings at the time of its intervention only and within the limits of Client's instructions, if any. The Company's sole responsibility is to its Client and this document does not exonerate parties to a transaction from exercising all their rights and obligations under the transaction documents. Any unauthorized alteration, forgery or falsification of the content or appearance of this document is unlawful and offenders may be prosecuted to the fullest extent of the law.

Attention: To check the authenticity of testing /inspection report & certificate, please contact us at telephone: (86-755) 8307 1443, or email: [CN.Doccheck@sgs.com](mailto:CN.Doccheck@sgs.com)

Page No.: 6 of 9

SGS-CSI Standards Technical Services Co., Ltd.  
Consumer and Retailer Technical Services

5/F, B-4 Building, Zijin (Baixia) Technology Incubation Special Park, No.1 Guanghua Road, Nanjing, China 210014 t (86-25) 87128385 f (86-25) 83407773 www.sgs.com.cn  
中国·南京·秦淮区光华路1号紫金白下创业特别社区4号楼B幢5楼 邮编: 210014 t (86-25) 87128385 f (86-25) 83407773 e as.cn@sgs.com

## Part G: Working Environment

### Section 1: Working Environment

1.1 Welfare Benefits		
Item	Content	Observations /Comments
1	Does the company have effective procedures to verify the age of staff at the time of recruitment?	<input checked="" type="checkbox"/> Has written procedure and keeps adequate age documents of workers <input type="checkbox"/> Has written procedure but doesn't follow records <input type="checkbox"/> Hasn't written procedure or follows records
2	Do all workers sign employment contracts with the factory?	<input checked="" type="checkbox"/> All workers sign employment contracts <input type="checkbox"/> Some workers sign employment contracts <input type="checkbox"/> Only management staff sign employment contracts <input type="checkbox"/> No staff sign employment contracts
3	Is statutory contribution required for all employees' social insurance (e.g. health insurance, unemployment insurance, accident insurance etc.) paid for by the enterprise?	<input checked="" type="checkbox"/> All workers have social insurance. <input type="checkbox"/> Some workers have social insurance <input type="checkbox"/> Only management staffs have social insurance <input type="checkbox"/> No staff have social insurance
4	Does the company have a clear and effective policy on working hours, rest and vacations? If does, please list it.	<input checked="" type="checkbox"/> All staffs work kept to the policy <input type="checkbox"/> Most of the time it keeps to the policy except midseason. <input type="checkbox"/> Usually needs overtime. <input checked="" type="checkbox"/> No relevant records for working hours Describe the working hours: 8 hours/day, 5 working days/week
5	Does the company pay extra remunerations for all overtime work?	<input checked="" type="checkbox"/> For all overtime work. <input type="checkbox"/> For official holidays <input type="checkbox"/> For official holidays except weekend. <input type="checkbox"/> No extra remunerations for overtime.
6	Does the company have dormitories for staff? If yes, please describe the condition.	<input type="checkbox"/> Provide dormitories for all staff <input type="checkbox"/> Provide dormitories for workers <input type="checkbox"/> Provide dormitories for management staff <input checked="" type="checkbox"/> No dormitories were provided. Describe the condition: N/A
1.2 Labor Protection		
Item	Content	Observations /Comments
1	Are there uniforms for all staff in company?	<input type="checkbox"/> Yes <input checked="" type="checkbox"/> No <input type="checkbox"/> Other
2	Is the emergency medical supplies enough and easily used in workshop?	<input type="checkbox"/> Yes <input type="checkbox"/> No <input checked="" type="checkbox"/> Other Remark: This audited site is an office without workshop.
3	Does the company arrange health and safety training for new workers?	<input type="checkbox"/> Yes <input checked="" type="checkbox"/> No <input type="checkbox"/> Other
4	Do the workers have the appropriate protective equipment during operation in workshop? Such as gloves, masks.	<input type="checkbox"/> Yes <input type="checkbox"/> No <input checked="" type="checkbox"/> Other Remark: They don't need the protective equipment.
5	Is there training needed and carried out for fire protection?	<input checked="" type="checkbox"/> Yes <input type="checkbox"/> No <input type="checkbox"/> Other



Unless otherwise agreed in writing, this document is issued by the Company under its General Conditions of Service accessible at <http://www.sgs.com/en/Terms-and-Conditions.aspx> Attention is drawn to the limitation of liability, indemnification and jurisdiction issues defined therein. Any holder of this document is advised that information contained hereon is solely limited to visual examination of the safely and readily accessible portions of the consignment and reflects the Company's findings at the time of its intervention only and within the limits of Client's instructions, if any. The Company's sole responsibility is to its Client and this document does not exonerate parties to a transaction from exercising all their rights and obligations under the transaction documents. Any unauthorized alteration, forgery or falsification of the content or appearance of this document is unlawful and offenders may be prosecuted to the fullest extent of the law.

Attention: To check the authenticity of testing/inspection report & certificate, please contact us at telephone: (86-755) 8307 1443, or email: [CN.Doccheck@sgs.com](mailto:CN.Doccheck@sgs.com)

Page No.: 7 of 9

5/F, B-4 Building, Zijin (Baixia) Technology Incubation Special Park, No.1 Guanghua Road, Nanjing, China 210014 t (86-25) 87128385 f (86-25) 83407773 www.sgs.com.cn  
 中国·南京·秦淮区光华路1号紫金白下创业特别社区4号楼B幢5楼 邮编: 210014 t (86-25) 87128385 f (86-25) 83407773 e as.cn@sgs.com

## Part J: Photos

### Section 1: Photos of Documents

#### 1.1 Photos of Documents

<p><b>Description: Business License</b></p> 	<p><b>Description: Export License</b></p> 
<p><b>Description: Custom Registration</b></p> 	<p><b>Description: Lease Agreement</b></p> 



Unless otherwise agreed in writing, this document is issued by the Company under its General Conditions of Service accessible at <http://www.sgs.com/en/Terms-and-Conditions.aspx>. Attention is drawn to the limitation of liability, indemnification and jurisdiction issues defined therein. Any holder of this document is advised that information contained hereon is solely limited to visual examination of the safely and readily accessible portions of the consignment and reflects the Company's findings at the time of its intervention only and within the limits of Client's instructions, if any. The Company's sole responsibility is to its Client and this document does not exonerate parties to a transaction from exercising all their rights and obligations under the transaction documents. Any unauthorized alteration, forgery or falsification of the content or appearance of this document is unlawful and offenders may be prosecuted to the fullest extent of the law.

Attention: To check the authenticity of testing/inspection report & certificate, please contact us at telephone: (86-755) 8307 1443, or email: [GM.Doccheck@sgs.com](mailto:GM.Doccheck@sgs.com)





Page No. 8 of 9

5/F, B-4 Building, Zijin (Baixia) Technology Incubation Special Park, No.1 Guanghua Road, Nanjing, China 210014 t (86-25) 87128385 f (86-25) 83407773 www.sgs.com.cn  
 中国·南京·秦淮区光华路1号紫金白下创业特别社区4号楼B幢5楼 邮编: 210014 t (86-25) 87128385 f (86-25) 83407773 e as.cn@sgs.com



## Section 2: Photos of Company

### 2.1 Photos of Company and Product Sample

<p>Description: Company Gate</p>	<p>Description: Office</p>
	
<p>Description: Showroom</p>	<p>Description: Product Samples</p>
	
<p>Description: Product Samples</p>	
	

-- End of the Report --



Unless otherwise agreed in writing, this document is issued by the Company under its General Conditions of Service accessible at <http://www.sgs.com/en/Terms-and-Conditions.aspx> Attention is drawn to the limitation of liability, indemnification and jurisdiction issues defined therein. Any holder of this document is advised that information contained hereon is solely limited to visual examination of the safely and readily accessible portions of the consignment and reflects the Company's findings at the time of its intervention only and within the limits of Client's instructions, if any. The Company's sole responsibility is to its Client and this document does not exonerate parties to a transaction from exercising all their rights and obligations under the transaction documents. Any unauthorized alteration, forgery or falsification of the content or appearance of this document is unlawful and offenders may be prosecuted to the fullest extent of the law.

Attention: To check the authenticity of testing/inspection report & certificate, please contact us at telephone: (86-755) 8307 1443, or email: [CN.Doccheck@sgs.com](mailto:CN.Doccheck@sgs.com)